



Step Lifts

Domestic Exterior or Interior Wheelchair Lifts

Terry
total lift solutions

The Mobility Lift Specialists
Trusted for over 50 years

MMS
MEDICAL

www.mmsmedical.ie

Call 021 4618000 for free and impartial advice

simple

AND PRACTICAL SOLUTION TO ACCESSING A HOME



Our **Terry Step Lift (TSL) range** offer an easy solution for wheelchair access to and from a domestic property including access to the garden. The lifts are versatile and flexible, and our experienced engineers can usually install a TSL in less than a day.

A ramp may not always be a feasible option due to lack of space or not enough length to achieve the required gradient. Terry Step Lifts provide a safe and reliable way to gain independent access into and out of a domestic property.

Three models are available to cater for every need. The TSL 500 and 1000 have a load capacity of 250 kg and they can travel up to 500 and 1000 mm respectively (or 960 mm, when a triple bridging step unit is supplied). The TSL 1000W, a wider model, is designed to carry heavy wheelchairs, mobility scooters and bariatric users. It has a load capacity of 385 kg* with a maximum travel height of 1000 mm.

Consisting of a self-contained unit, Terry Step Lifts are suitable for mounting on a flat 100 mm concrete base and are quick to install. Bridging steps can be added allowing easy pedestrian access via the same doorway.



WHY INSTALL A TERRY *step lift?*

- ✓ **Quickly installed** requiring minimal exterior alterations
- ✓ **Versatile solution** with a choice of bridging steps or upper level gate protection
- ✓ Can be **easily re-sited** and often a cheaper option than a ramp
- ✓ **Safe, reliable and easy to use**
- ✓ **Large load capacity TSL 1000W model available (385kg)** ideal for bariatric users*
- ✓ **Manufactured in Great Britain** to BS 6440 standard and CE marked

* Excluding bridging steps



	TSL 500	TSL 1000	TSL 1000W
Application range	External or internal use		
Max safe working load	250 kg	250 kg	385 kg
Max travel	500 mm	1000 mm	1000 mm
Internal platform width	800 mm	800 mm or 900mm wide option	1100 mm
Options	<ul style="list-style-type: none"> ✓ Handrails ✓ Single step bridging ✓ Remote control enabler ✓ Remote up/down control ✓ Upper gate and interlock ✓ Upper gate interlock kit 	<ul style="list-style-type: none"> ✓ Single, double or triple step bridging ✓ Radio control enabler ✓ Remote up/down control ✓ Pit installation (indoor only) ✓ Upper gate interlock kit ✓ Pit installation (indoor only) 	<ul style="list-style-type: none"> ✓ Bridging steps 900mm wide ✓ Radio control enabler ✓ Remote up/down control ✓ Upper gate and interlock ✓ Upper gate interlock kit ✓ Pit installation (indoor only) ✓ Steel or plexi-glass side infills ✓ Stainless steel in lieu of grey powder coat paint finish
Closed height	75 mm		
Power supply electrical requirements	220 / 240 V-50 / 60 Hz-13 A single phase		
Low voltage control system	24 V DC		
Operating temperature range	-10°C to +40°C		
Safety	Automatic wheelchair arrestor mechanism and full battery back-up. Constant pressure controls. Underside safety surface.		
Drive	Hydraulic scissor mechanism		

N.B. Maximum load, travel and dimensions may alter subject to lift specification. This would be determined with a survey.
Provides for wheelchair access only. However, should you require a lift to carry a wheelchair and an attendant or for standing use only, Terry Melody 1 and 3 lifts are designed for this purpose.

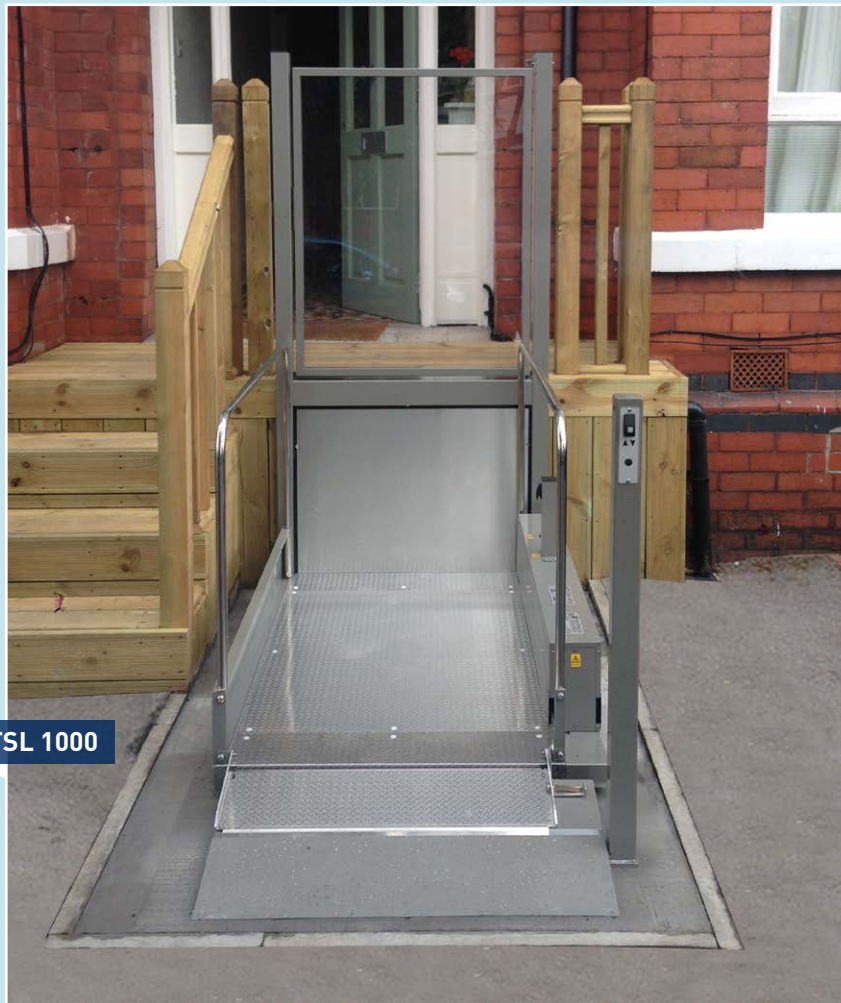

TSL 1000

Dimensions

All dimensions in mm

TSL 500

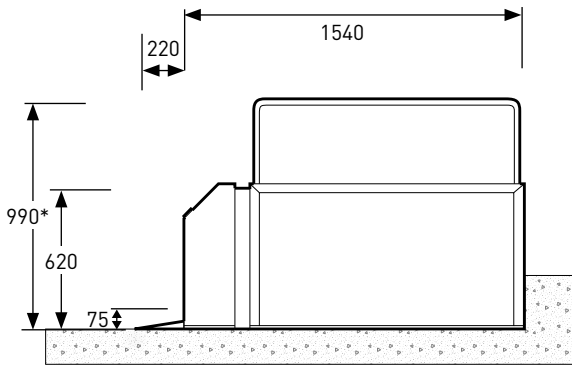
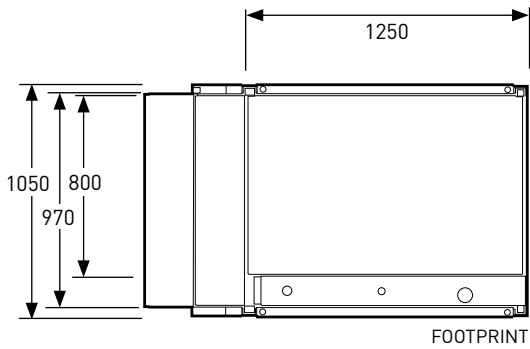

Handrails shown are an optional extra

TSL 1000

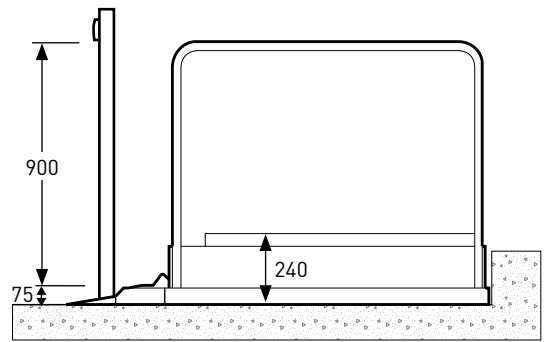
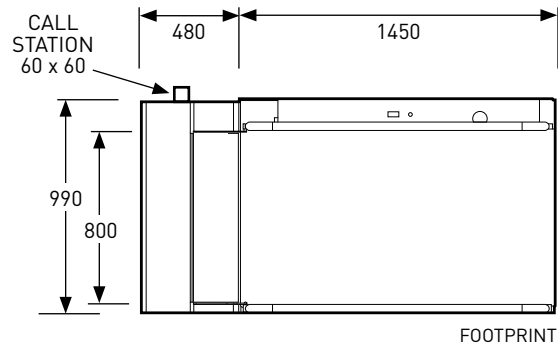

TSL 1000W

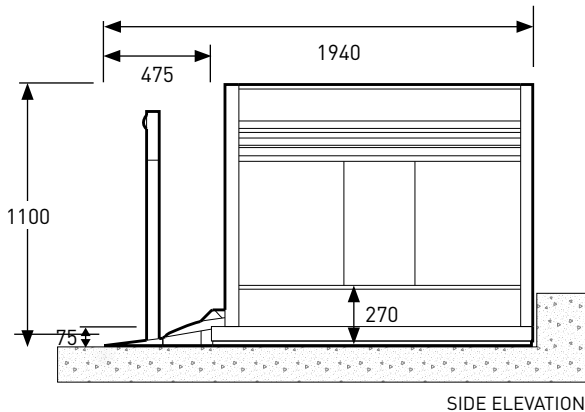
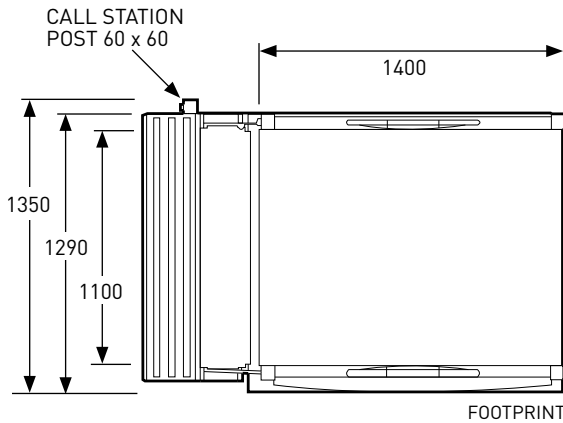

The Terry Lifts Guarantee



✓ **Origin:** Designed & manufactured in Great Britain with over 50 years' experience

✓ **Safety:** Full safety features

✓ **Certification:** ISO 9001:2015, ISO 14001:2015, OHSAS 18001:2007

✓ **Fully compliant:** British Standard BS6440:2011, CE marked



Call MMS Medical today on: **021 4618000**
or e-mail: info@mmsmedical.ie

MMS Medical,
51 East Gate Drive,
Little Island,
Cork T45 EA06

Terry
total lift solutions

T: 021 4618000
E: info@mmsmedical.ie

www.mmsmedical.ie