

www.mmsmedical.ie



Cork (Head Office)
MMS Medical Limited
51 Eastgate Drive
Little Island
Cork
Tel. 021 461 8000
Fax. 021 461 8099

Dublin
Unit 81
Western Parkway
Business Park
Lwr Ballymount Road
Dublin 12
Tel: 01 450 0582
Fax. 01 456 5889

Galway
Units 2&3
Kilkerrin Park
Liosban
Tuam Road
Galway
Tel. 091768868
Fax. 091 768869

Full No Obligation Design & Quotation Service

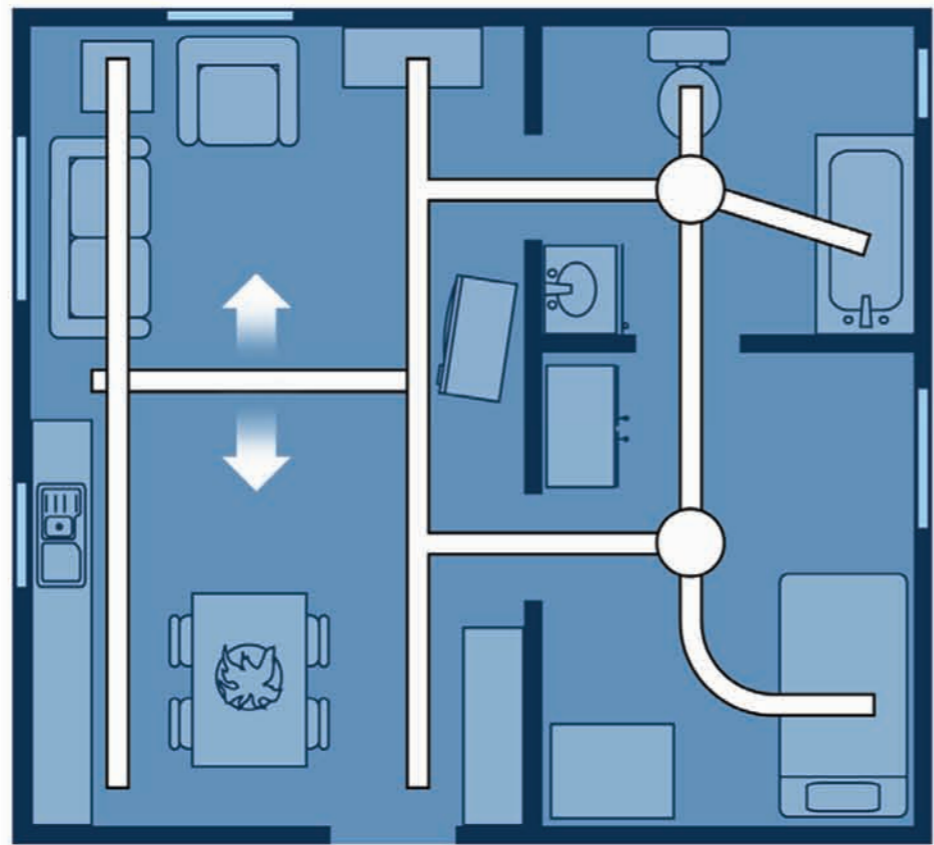

Dimensions

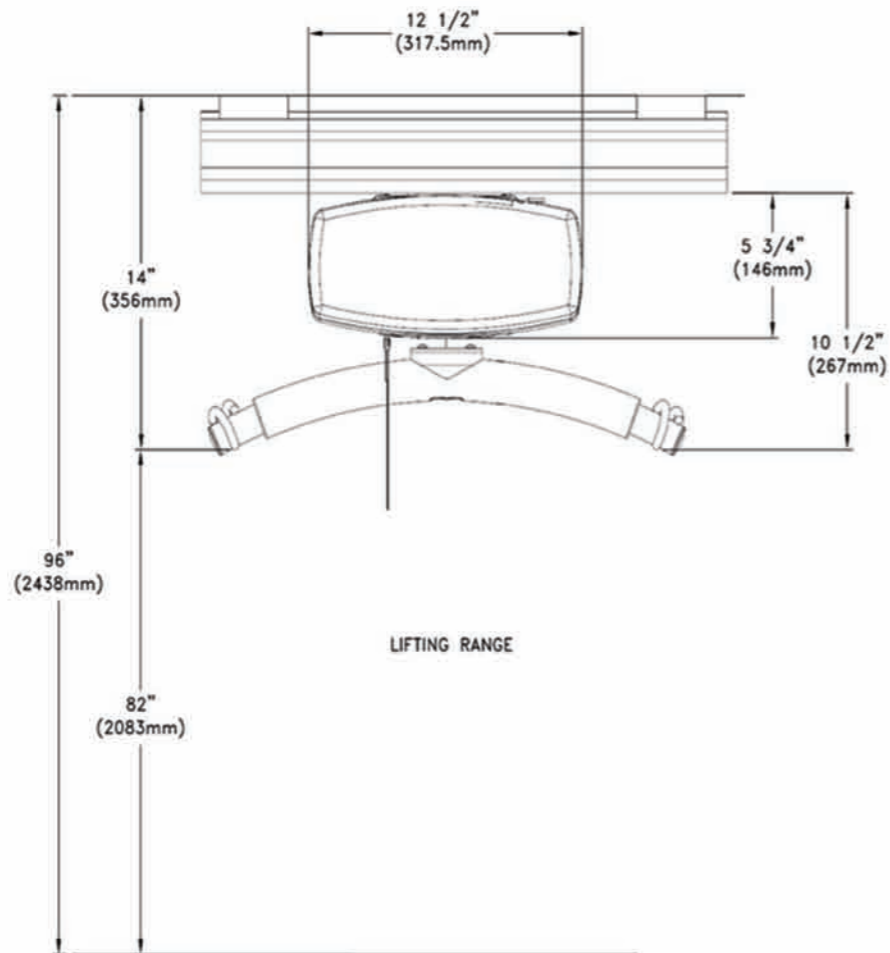

easicare



COMPACT AND CLASS LEADING OVERHEAD HOIST



easicare



COMPACT AND CLASS LEADING OVERHEAD HOIST

FEATURES

- Compact, Smooth and Quiet
- SWL 130Kg (20st) - 160Kg(25st) - 200Kg (31st) - 270Kg (42st)
- Optional Manual or Powered Traverse
- Greater Lifting / Traverse Speed
- Ergonomically Designed Handset
- InTrack Charger
- Slimline Spreader Bar
- Numerous Safety Features
- State of the Art Diagnostics
- LCD Operation Display
- Return to Charge (optional)
- Emergency Stop / Lower
- Emergency Winder

Can be ceiling mounted, floor mounted and wall mounted

transactive™
tra



transactive™
tra

This state of the art overhead hoist comes with the latest features as standard and optional accessories for the most demanding situations. It is truly compact in size and extremely quiet, yet provides a great lifting range and includes the best diagnostics in its class. The highly competitive price completes the offering, making it one of the most attractive hoist systems on the market today.

Accessories

- Slimline Spreader Bar
- Bariatric Carry Bar
- In Track Charger
- Emergency Wind Up / Down
- Pneumatic Handset
- Manual & Powered Turntable
- Transition Gate



Specification

Max Safe Working Load -	130 / 160 / 200 /270Kg 20st / 25st / 31st / 42st
Approx Lifts Between Charge -	65 with 85Kg load
Unit Weight Inc Batteries -	10.4Kgs (manual 9.7Kg)
Lifting Speed Loaded -	0.15m/s (0.25m/s unloaded)
Batteries -	2 x 12v 5amp
Voltage -	24v DC
Transformer -	IP67 Rated 50/60mHz 30v AC Output 230v AC input