



Melody 3

Platform Lift

www.terrylifts.co.uk

The reliable solution for your wheelchair lifting needs.



The **Melody 3 Platform Lift** is the perfect solution for easy wheelchair access both outside and inside of a property. The lift provides a maximum travel of 3 metres and is available in two platform sizes.

Accessing a domestic property independently is easy with the Melody 3. In public buildings, the lift provides a reliable solution and allows for compliance with the current disability legislation.

When you choose the Melody 3, your lift will be installed quickly and easily. An integral ramp eliminates the requirement for a pit, which keeps building work to a minimum.

User safety and comfort are in the heart of the design. The lift is equipped with safety surfaces and a battery back-up. The powered carriage and landing gate options allow for even easier access and egress.

Independent access to your property – quick and easy.

- **Quick installation**
- Integral ramp **keeps building work to a minimum**
- Option of **automatic gates** for even easier access and egress
- **Aesthetically pleasing** solution due to the attractive design and lack of a mast or support tower
- **Complies with BS6440:2011** and Part M of the Building Regulations
- Available in **two platform sizes**: 900 mm x 1400 mm (standard) and 1100 mm x 1400 mm
- **Max load of 500 kg** for lift travels up to 2 m and 440 kg from 2 m up to 3 m





Specification

Finish: Painted carriage and upper level landing gate with polycarbonate infills

Useable platform area: 900 mm x 1400 mm

Integral ramp: Eliminates the requirement for a pit – minimises building work

Maximum safe working load:
500 kg up to 2 m / 440 kg up to 3 m

Maximum travel: 3 m (3000 mm)

Minimum travel: 750 mm

Rated speed: 0.08 metres per second

Power supply electrical requirements:
Dedicated 240 V AC~ 50 Hz 13 A single phase
RCD Protected Supply

Low voltage operating system: 12 VDC

Hydraulic oil grade: T22

Operating temperature range: -10 °C to +40 °C

Safety: Safety surfaces protect against entrapment below the platform. The lift has battery back-up for emergency lowering only. Hose burst valve on the ram. Chequer plate floor.

Lifting mechanism:
Direct acting hydraulic drive system

IP rating: Control stations IP53X

Corrosion resistant materials (All visible components):
Aluminium. Polyester Powder Coating applied to either galvanised or zintec steel sheet or active zinc primer.

Design and manufacturing standard:
2006/42/EC Machinery Directive, (CE Mark),
and BS6440 (2011).

Available options

- Powered platform and landing gates
- 1100 mm x 1400 mm platform
- Dual car controls
- Full battery back up
- Stainless Steel Kit: All handrail posts, kicking strips, platform trims, upper handrail panels and covers
- Pit Installation (indoor installation only)
- Remote Enabler or Remote Isolate (extra fobs available)
- Stand alone call station in post - stainless steel or painted finish
- Wall mounted surface or flush call stations
- Special paint finishes
- Various non-slip vinyl floor coverings
- LED down lights
- GPRS autodialler for 2 way voice communication

Dimensions

All dimensions in mm

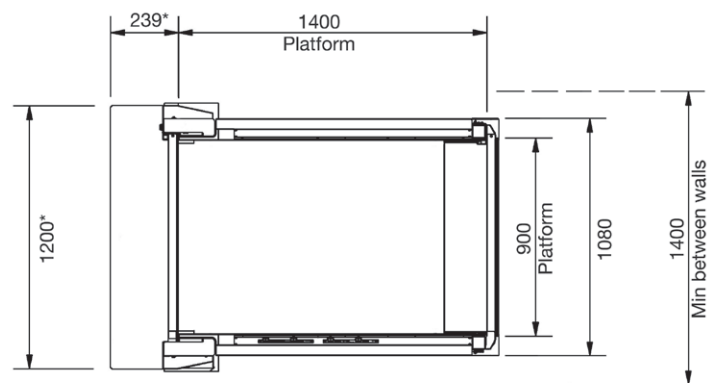

* Upper level fixing plate

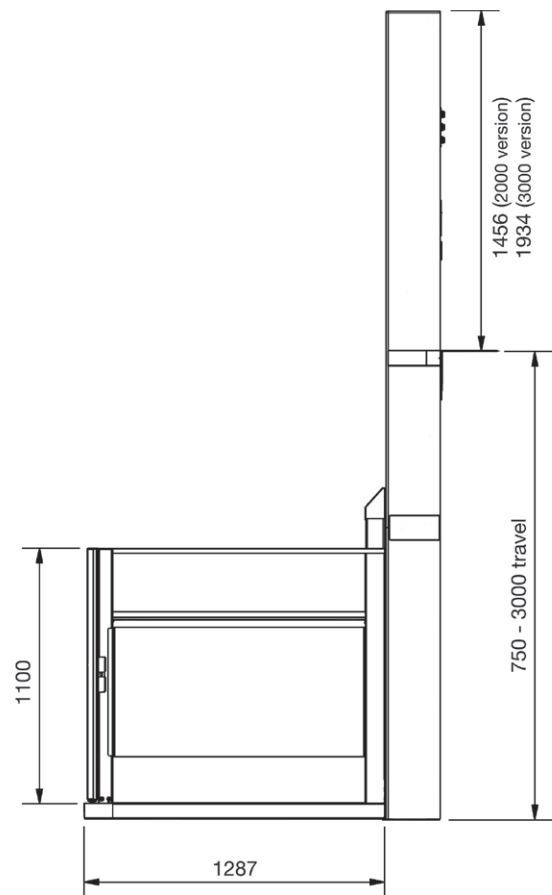

Issue date: 5/2016

Call **MMS Medical** today on: **021 4618000** or
e-mail: **info@mmsmedical.ie**



MMS Medical
51 Eastgate Drive,
Little Island,
Cork
T: 021 4618000 E: info@mmsmedical.ie
www.mmsmedical.ie

